



TILLOTSON LTD., CLASH INDUSTRIAL ESTATE,
TRALEE, CO. KERRY, IRELAND

PHONE: +353 66 7121911 FAX: +353 66 7124503

e-mail: sales@tillotson.ie



SERVICE MANUAL

INTRODUCTION

Tillotson has developed the HR Series Diaphragm carburetor for engines with a displacement of from 12 to 25 cubic inches per cylinder. It is available as a complete fuel system including carburetor, integral fuel pump and filter for two stroke cycle engines or as a carburetor and integral fuel filter for four stroke cycle engines.

The diaphragm controlled metering system allows precise fuel metering to the engine at extreme tilt angles and prevents fuel level changes due to vibration. The dual venturi used in this model series multiplies the venturi pressure drop causing fine atomisation of the fuel that is delivered from the main fuel nozzle so that the fuel reaches the engine as a combustible fog instead of a fluid stream. The main benefit of this venturi system is increase power and fuel economy.

Designed with a minimum number of parts, this compact unit has retained the dependability and easy servicing features of the smaller Tillotson diaphragm carburetor that have been in use throughout the world for several years.

Information contained in the following pages is presented as an aid to understanding the construction, operation and servicing of the HR series carburetor.



SERVICE MANUAL

CARBURETOR ADJUSTMENT

The high speed and idle mixture screws have normal right hand screws thread. These adjustments are turned closed wise to close, or lean the mixture, and counter-clockwise to open, or enrich the mixture. The starting adjustment opening for a new unit, or a carburetor that has not been run on the engine, is one full turn open on both the high speed and idle mixture screws.

The idle speed screw should be adjusted to open the throttle shutter a small amount. This adjustment should be carefully made on vehicles that have a centrifugal clutch drive arrangement; a very high idle speed may cause the clutch to engage and the vehicle may start to move.

Open the fuel line shut off valve, if your engine is equipped with one, and close the choke shutter. Open the throttle about one quarter of full travel and firmly pull the starting cord until the engine fires. Open the choke shutter far enough to allow the engine to idle until it has warmed up enough to run continuously with the choke fully open. Do not race a cold engine.

Adjust the idle mixture screw to obtain a smooth, steady idle, and re-adjust the idle speed screw to obtain the idle speed recommended by the engine manufacturers. Re-check the idle mixture adjustment at the recommended idle speed. An over rich idle mixture will cause the engine to fire unevenly and there will be smoke from the exhaust. A lean idle mixture will usually cause back firing.

The high speed mixture screw should be adjusted with the engine at fully open throttle and under normal full load. The mixture should be adjusted to allow the engine to operate at highest RPM. The speed will decrease with either an over rich mixture or lean mixture.

The above procedure need not be repeated each time the engine is started. The adjustment will remain in position and will not require frequent re-adjustment.

After the carburetor has been correctly adjusted, the engine should start easily. To start a cold engine, close the choke shutter, open the throttle about one quarter of full travel, firmly pull the starting cord until the engine starts, open the choke far enough to allow the engine to idle until it has warmed up and can run continuously with the choke fully open.

To start a warm engine, pull the starting cord. It should not be necessary to use the choke unless the engine is overheated and fuel vapor is present in the fuel lines

**... DO NOT FORCE
MIXTURE SCREWS
INTO THEIR SEATS !**

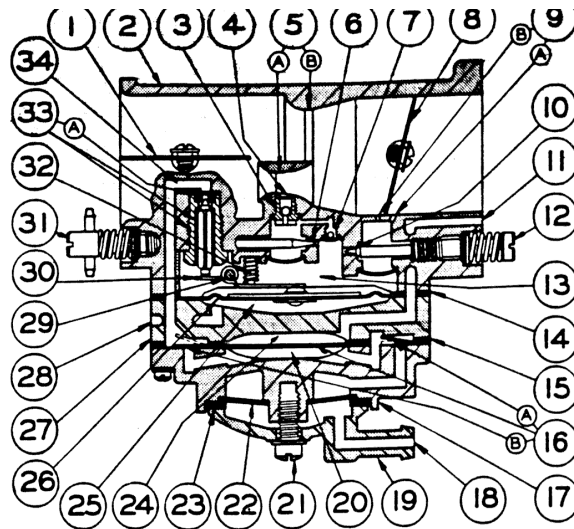

HR SERIES CARBURETOR NOMENCLATURE

1. CHOKE SHUTTER
2. BODY
3. MAIN FUEL CHECK VALVE
4. MAIN FUEL DISCHARGE PORT
- 5A. PRIMARY VENTURI
- 5B. SECONDARY VENTURI
6. HIGH SPEED MIXTURE ORIFICE
7. POWER VALVE
8. THROTTLE SHUTTER
- 9A. PRIMARY IDLE DISCHARGE PORT
- 9B. SECONDARY IDLE DISCHARGE PORT
10. IDLE MIXTURE ORIFICE
11. IMPULSE PORT
12. IDLE MIXTURE SCREW
13. METERING CHAMBER
14. DIAPHRAGM GASKET
15. FUEL PUMP GASKET
16. FUEL PUMP DIAPHRAGM
- 16A. PUMP DIAPHRAGM INLET VALVE
- 16B. PUMP DIAPHRAGM OUTLET VALVE
17. FUEL PUMP COVER
18. FUEL INLET
19. STRAINER COVER
20. FUEL PUMP CHAMBER
21. STRAINER COVER RETAINING SCREW
22. FUEL STRAINER SCREEN
23. STRAINER COVER GASKET
24. PULSE CHAMBER
25. ATMOSPHERIC CHAMBER
26. METERING DIAPHRAGM
27. DIAPHRAGM COVER
28. ATMOSPHERIC VENT
29. FULCRUM PIN
30. INLET CONTROL LEVER
31. HIGH SPEED MIXTURE SCREW
32. INLET TENSION SPRING
33. INLET NEEDLE & SEAT
- 33A. INLET SEAT GASKET
34. FUEL INLET SUPPLY CHANNEL

SEE FOLLOWING PAGES
FOR OPERATIONAL DATA

OPTIONAL CONFIGURATIONS

METERING DIAPHRAGM COVER DIAPHRAGM GASKET IDLE FUEL MIXTURE SCREW IDLE FUEL

.....

for the HR Model Carburetor

The Model HR carburetor is also available with a plain diaphragm cover plate. The fuel must come from a separate fuel pump or an overhead fuel tank for a gravity fuel supply for these two optional models.

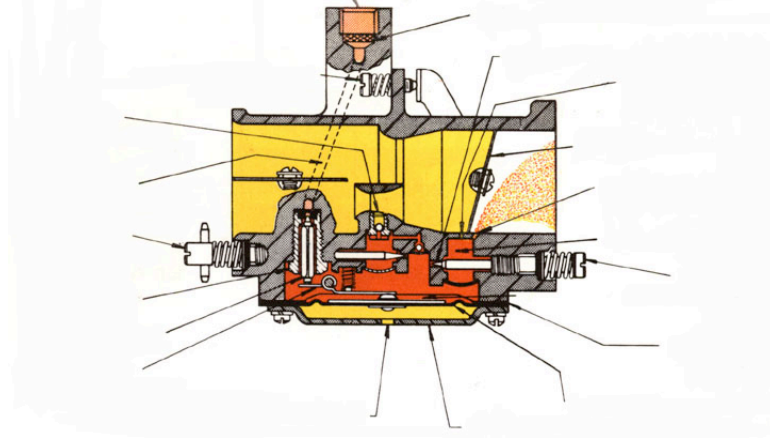

FUEL INLET INLET VALVE DIAPHRAGM IDLE FUEL SUPPLY CHANNEL PRIMARY IDLE FUEL DISCHARGE PORT SECONDARY

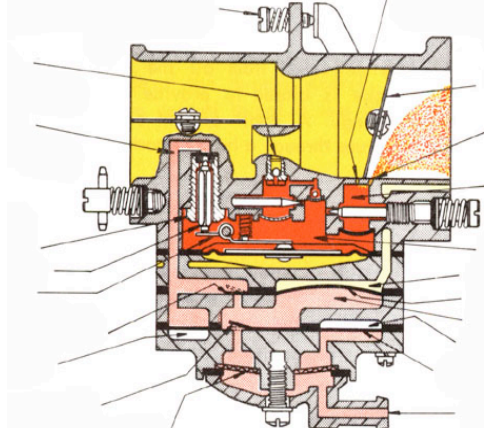

The pulse cycle forces the fuel pump



FUEL PUMP OPERATION

The fuel pump is a pulse operated diaphragm pump. The pressure-vacuum pulse is supplied from the engine crank case where the pulse cycles are created by the reciprocating action of the engine piston. Crankcase pulse is transmitted to the pump pulse chamber through the fuel pump pulse port in the mounting flange of the carburetor body. The vacuum part of the pulse cycle causes the fuel pump diaphragm to move into the pump pulse chamber creating a vacuum in the fuel pump chamber that allows fuel to flow from the fuel inlet through the fuel strainer screen, past the inlet check valve and into the fuel pump chamber. The vacuum in the fuel pump chamber closes the outlet check valve during this part of the pumping cycle.

The pressure part of the pulse cycle forces the fuel pump diaphragm into the fuel pump chamber creating a pressure on the fuel that forces it out of the fuel pump chamber through the outlet check valve, and through the fuel inlet supply channel to the inlet needle valve. The fuel pressure closes the inlet check valve during this part of the pumping cycle.

The inlet and outlet surge chambers diminish the pressure surges of the fuel and provide steady fuel flow through the pump system.

HR

CARBURETOR

DIAPHRAGM BUTTON IMPULSE PORT TO PUMP SECONDARY IDLE FUEL DISCHARGE PORT

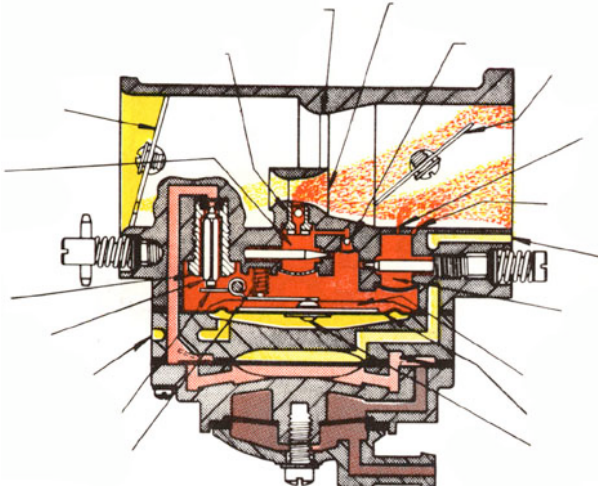

the fuel side of the metering diaphragm. Atmospheric air pressure on the opposite side will force the metering diaphragm upward causing the diaphragm button to contact the inlet control lever and overcome the inlet tension spring pressure, permitting fuel under pressure to force the needle off its seat and enter the metering chamber. The fuel then travels from the metering chamber up through the idle and main fuel supply orifices and channels and out the discharge ports to the engine.

STARTING (choke) OPERATION

Starting an engine with the HR carburetor involves the same methods that are used in a conventional float type carburetor. As the engine is cranked with the choke in the closed position, engine suction will be transmitted to the diaphragm fuel chamber through both primary and secondary idle discharge ports as well as the main fuel discharge port, creating a low pressure area on

Fuel is delivered from all the discharge ports when the choke is closed to provide a full, rich mixture for starting. A small amount of air is added to this rich mixture through a hole or port in the choke shutter.

IDLING OPERATION

The throttle shutter is a partially open position when the engine is idling. Engine suction is transmitted through the primary idle fuel discharge port to the fuel chamber side of metering diaphragm via the idle fuel supply channel. Again, the metering diaphragm is forced upward by atmospheric pressure depressing the inlet control lever and permitting fuel under pressure to force the inlet needle off its seat and enter the metering chamber. The fuel is then drawn up through idle fuel adjustment orifice and delivered to the engine through primary idle discharge port.

The entire carburetor bore from the air inlet to the back of the throttle shutter is at atmospheric pressure during idle operation. the ball check valve in the main fuel port is closed to prevent air from entering the metering chamber.

In all phases of operation, the amount of fuel entering the metering chamber is equal to the amount of fuel being used by the engine.

DIAPHRAGM GASKET PRIMARY IDLE FUEL DISCHARGE PORT THROTTLE SHUTTER FUEL INLET

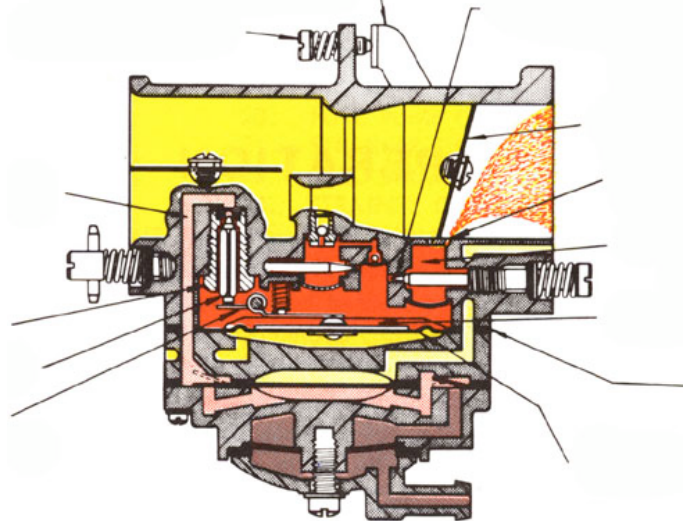

OPERATIONAL DATA

FUEL STRAINER GASNET SECONDARY IDLE FUEL DISCHARGE PORT THROTTLE SHUTT

Intermediate Operation

Fuel is delivered into and through the carburettor in the same manner as when the engine is idling. However, as the throttle opens and engine speed increases, more fuel is demanded from the carburettor and supplied to the engine by the secondary idle discharge port located immediately behind the throttle shutter. As the throttle shutter continues to open and engine speed increases, the velocity of air through the venturi creates a low pressure area at the venturi throat and diminishes the suction on engine side of the throttle shutter. When the pressure at the venturi throat is less than that existing within metering diaphragm fuel chamber, fuel is drawn up through high speed mixture screw orifice and out main fuel discharge port.

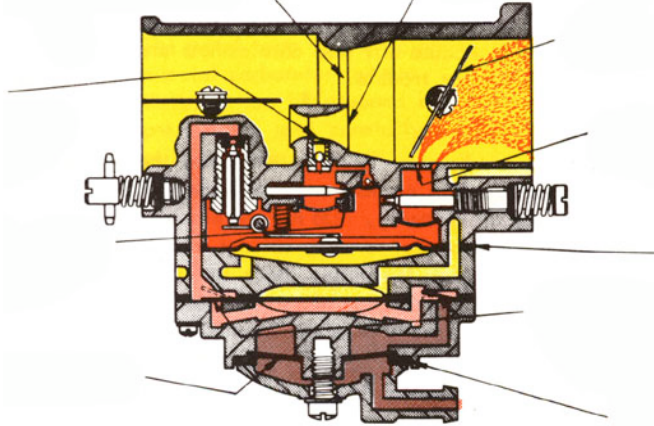

High Speed Operation

As the throttle shutter progressively opens from intermediate position to full open position, the air velocity through the venturi increases and fuel is metered up through high speed mixture screw orifice and main fuel discharge port in accordance with the power requirements of the engine. The action of the metering diaphragm is the same as previously described with suction required to operate the diaphragm being transmitted through the main fuel discharge port.

Fuel Pump Operation

The fuel pump is a pulse operated diaphragm type, where the inlet and outlet check valves are flap valves. The pumping pulse is supplied from the changes in engine base pressure caused by the motion of the piston.

HIGH SPEED MIXTURE SCREW ORIFICE THROTTLE SHUTTER MAIN FUEL DISCHARGE PORT PRIMARY VENTURI METERING DIAPHRAGM SUPPLY FI

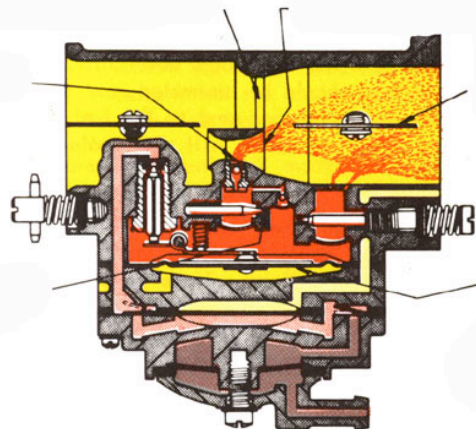

SERVICE DATA

HOW TO DISASSEMBLE FOR CLEANING AND REPAIR

The model HR carburetor should be cleaned and inspected at regular intervals, depending on the service conditions.

Select a clean work area because dirt and carelessness are the causes of most carburetor trouble.

CAUTION:

Some solvents and cleaners have a damaging effect on the synthetic rubber parts used in carburetors. It is best to use a petroleum product for cleaning. Do not use alcohol, acetone, lacquer thinner, benzol or any solvent with a blend of these ingredients unless the rubber parts and gaskets are removed. If you are in any doubt about your solvent, test a used part in it and observe the reaction.

The entire carburetor should be cleaned by flushing with fuel and blown dry with compressed air before disassembly. The carburetor should be inspected for cracks in the casting, bent or broken shafts, loose levers or swivels and stripped threads.

1 Inspect the idle speed screw, washer and tension spring. Inspect the casting for thread damage. In the event the casting is ripped or threads are damaged, repair by inserting an 8-32 Heli-coil 3/16" long.

2 The fuel inlet and filter cover are removed by removing the center screw. Remove the filter cover, the cover gasket and filter screen. The filter screen should be cleaned by flushing with fuel or solvent and blowing with compressed air. It is advisable to replace the gasket whenever the filter screen is serviced. Flush all dirt from the plastic cover before assembly.

3 Remove the six body screws and the fuel pump cover casting. Remove the fuel pump diaphragm and gasket. Inspect pump diaphragm; it must be flat and free from holes. The gasket should be replaced if there are holes or creases on its sealing surface. Be certain to re-assemble these parts in the correct order. The pump gasket the fuel pump diaphragm should be assembled next to the gasket and the flap valve member next to the fuel pump diaphragm so that the flap valves will seat against the fuel pump cover.

4 Remove the diaphragm cover casting, the metering diaphragm and diaphragm gasket. Inspect the diaphragm for holes, tears and imperfections. These parts must be re-assembled in the correct order. The diaphragm gasket is assembled onto the body casting first and the metering diaphragm is assembled next to the gasket.

5 Remove the fulcrum pin retaining screw, the fulcrum pin, inlet control lever and the inlet tension spring. Use caution in removing these parts because the spring pressure may cause the inlet lever to fly out of the casting. Inspect the parts for wear or damage. The inlet control lever must rotate freely on the fulcrum pin.

6 Handle the inlet spring carefully. Do not stretch this spring or in any way change its compression characteristics. If in doubt about its condition, replace it.

7 Remove the inlet needle. Remove the inlet seat assembly using a 5/16 inch thin wall socket wrench. Remove the inlet seat gasket.

The inlet seat assembly consists of a brass cage and a rubber insert for the inlet needle seat. The insert goes into the cage only one correct way. Looking at the insert, one side is flat and smooth; the other side has a ridge or rim moulded around the outside edge. This ridge is to be assembled away from the inlet needle point.

Some models of the HR carburetor are equipped with a rubber tipped needle, a brass inlet seat and a copper gasket. The installation instructions below are applicable to both types of inlet seats.

The inlet needles and seats are matched and tested for leaks at the factory and the parts should not be interchanged – they must be kept in matched sets. When installing the insert cage into the carburetor body, use a new gasket. Do not force the cage, as you may strip the threads or distort the insert. Use a torque wrench to apply 25 to 30 inch-pounds pressure. The needle and seat assembly must be clean to insure correct performance.

8 Remove and inspect the points of both the high speed and idle mixture screw. Notice the idle mixture screw point has the step designed to minimise point

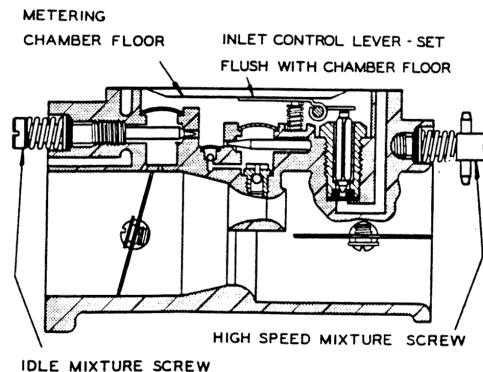

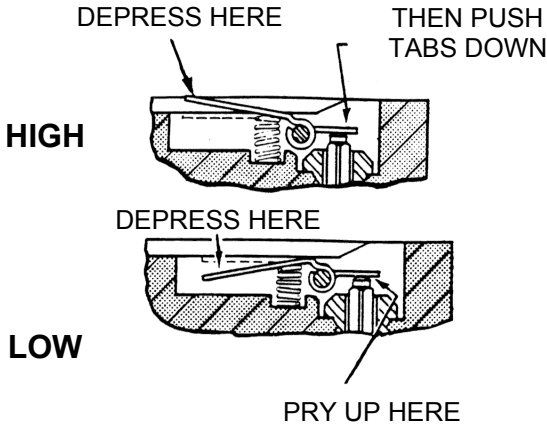

Be bent, extruded from being forced into the casting seat or possibly broken off in the casting. If either mixture screw is damaged, be sure to inspect the condition of the casting. If the adjustment seats are damaged, a new body casting is required.

9

The idle bypass ports and main nozzle ball check valve are sealed from the metering chamber by welch plugs. It is seldom necessary to remove either of these plugs because there is no wear in either section, and any dirt that may accumulate can usually be blown out with compressed air through the mixture screw holes. If the carburetor is unusually dirty and the welch plugs must be removed, it will require careful work. If the drill travels too deep into the cavity, the casting may be ruined. Pry the welch plug out of its seat, using a small punch. Inspect the idle bypass holes to insure they are not plugged. Do not push drills or wires into the metering holes. This may alter carburetor performance. Blow plugged holes clean with compressed air. Remove the main nozzle ball check assembly with a screwdriver of correct blade width. If this ball check is defective, the engine will not idle unless the high speed mixture screw is shut off or there will be poor high speed performance with the high speed mixture screw adjusted at 1-1/4 turns open. Replace the defective part.

10

The choke and throttle shafts may be removed if there is evidence of wear on these parts. The shafts do not have to be removed before cleaning the body casting if the parts are not worn.

Mark the throttle and choke shutters before removing them so that they can be re-assembled correctly. The edges are tapered for exact fit into the carburetor bores. Remove two screws and pull the shutter out of the carburetor body. Remove the throttle shaft clip and pull the shaft out of the casting. Examine

the shaft and the body bearings for wear. If the shaft shows excessive wear, replace it. If the body bearing areas are worn, replace the body casting. Remove the choke shaft from the body carefully so that the friction ball and spring will not fly out of the casing. Inspect the shaft and bushings.

11

Clean all parts before re-assembling the carburetor. The metal parts can be cleaned in a good grade of commercial carburetor solvent. If the carburetor is not very dirty, it can be cleaned by blowing the parts with compressed air and carefully blowing out each channel and orifice in the castings.

REPLACE ALL WORN PARTS

12

Assemble the carburetor. Make certain that all parts are kept clean before they are assembled to the body casting. Few measurements are required to complete the assembly of this simple unit:

1. Tighten the inlet seat to 25-30 inch-pounds of torque.
2. Adjust the inlet control lever so that the center of the lever that contacts the metering diaphragm is flush to the metering chamber wall as shown in the drawings.
3. Install new welch plugs at the nozzle well and bypass chamber if the original parts were damaged or removed. Place the new welch plug into the casting counter bore convex side up and flatten it to a tight fit, using a 5/16 inch flat end punch. If the installed welch plug is flat.
4. Assemble the gaskets, diaphragms and castings in the correct order.
5. Assemble the throttle shaft into the carburetor body and attach the throttle shaft clip before assembling the throttle shutter. With the shaft secured in place, assemble the shutter into the shaft. Make certain that the shutter fits accurately into the throttle bore in the closed position.
6. Assemble the spring and ball into the choke shaft hole and assemble the shaft into position. Assemble the shutter into the choke shaft. Make certain that the choke shutter fits tightly to the carburetor bore in the closed position.

A carefully rebuilt HR model carburetor should perform well. The two most likely causes of carburetor failure are dirty and a careless repair job. A clean, carefully assembled unit should be nearly as good as new.

• • • • See the following page for operational trouble and remedy data.

TROUBLE DATA

TROUBLE

POSSIBLE CAUSE

REMEDY

CARBURETOR FLOODS

- Dirt or foreign particles preventing inlet needle from seating** → Clean or replace the inlet needle and seat
- Stuck inlet Lever → Replace or clean
- Spring not seated on lever dimple → Correct the assembly
- Diaphragm Improperly installed → Correct or replace
- Plugged air filter → Clean Filter
- Faulty choke stop allowing choke to close → Replace choke shaft assembly
- Fuel tank pressure build-up → Check tank vent
- Inlet Lever adjusted too high → Adjust flush with chamber floor

ENGINE WILL NOT ACCELERATE

- Idle mixture too lean.** → Readjust
- Low inlet lever setting → Adjust Flush with chamber floor
- Carburetor loose on manifold → Tighten
- Diaphragm cover plate loose. → Tighten cover plate screws
- Diaphragm gasket leaking → Replace gasket
- Fuel channels plugged** → Clean carburetor
- No fuel** → Fill fuel tank

ENGINE WILL NOT IDLE

- Incorrect adjustment → Readjust
- Fuel channels plugged → Clean carburetor
- Inlet lever set incorrectly → Set flush with chamber floor
- Sticking inlet needle or lever → Replace or clean
- Pump pulse hole not aligned with flange hole → Align
- Throttle shutter cocked in the throttle bore causing fast idle. → Adjust shutter position
- Faulty nozzle check cage → Replace nozzle assembly
- Welch plug does not seal → Replace welch plug
- Diaphragm vent plugged → Clean
- Tank vent not operating → Repair

ENGINE RUNS OUT LEAN

- Fuel line plugged → Clean fuel line
- Leak in fuel system from tank to pump → Replace line
- Pump pulse hole plugged or not aligned with engine pulse hole → Clean or correct alignment
- Pump valve flippers damaged or bent off ports → Replace pump diaphragm
- Dirty inlet screen → Clean filters
- Clogged fuel channels → Clean carburetor
- Incorrect inlet lever adjustment → Set lever flush with chamber floor
- Low fuel supply → Fill fuel tank

CARBURETOR RUNS RICH WITH HIGH SPEED MIXTURE SCREW SHUT OFF

- Welch plugs not sealing → Replace welch plugs
- Ruptured pump diaphragm → Replace pump diaphragm
- Carburetor flooding → See above

NOTE: - Turn mixture screw carefully ■ ■ ■ DO NOT FORCE MIXTURE SCREWS INTO SEATS